

PNEUMATIC DRIVES

DRIVES FOR THE SPECIALIST



PNEUMATIC



ATEX



SYSTEM CONCEPT

FUNCTION

The main air supply (1) is connected to the 4/3-way motor control valve (2) and the hand-operated valve (3).

Pressing the push button (3a) on the hand-operated valve (3), the motor control valve (2) is actuated - the control piston (2a) opens the air way to the motor (4), dual stop valve (5) and the disc brake (6).

The air brake piston (6a) releases the brake disc and the motor (4) is rotating.

When the push button (3a) is released, the control piston (2a) reverts to its initial position, as shown in (2b), and bleeds the brake (6) and the motor (4) via the two lines (bled middle position).

The brake is locked through spring resistance.

If the air supply fails, the brake locks and the motor stops.

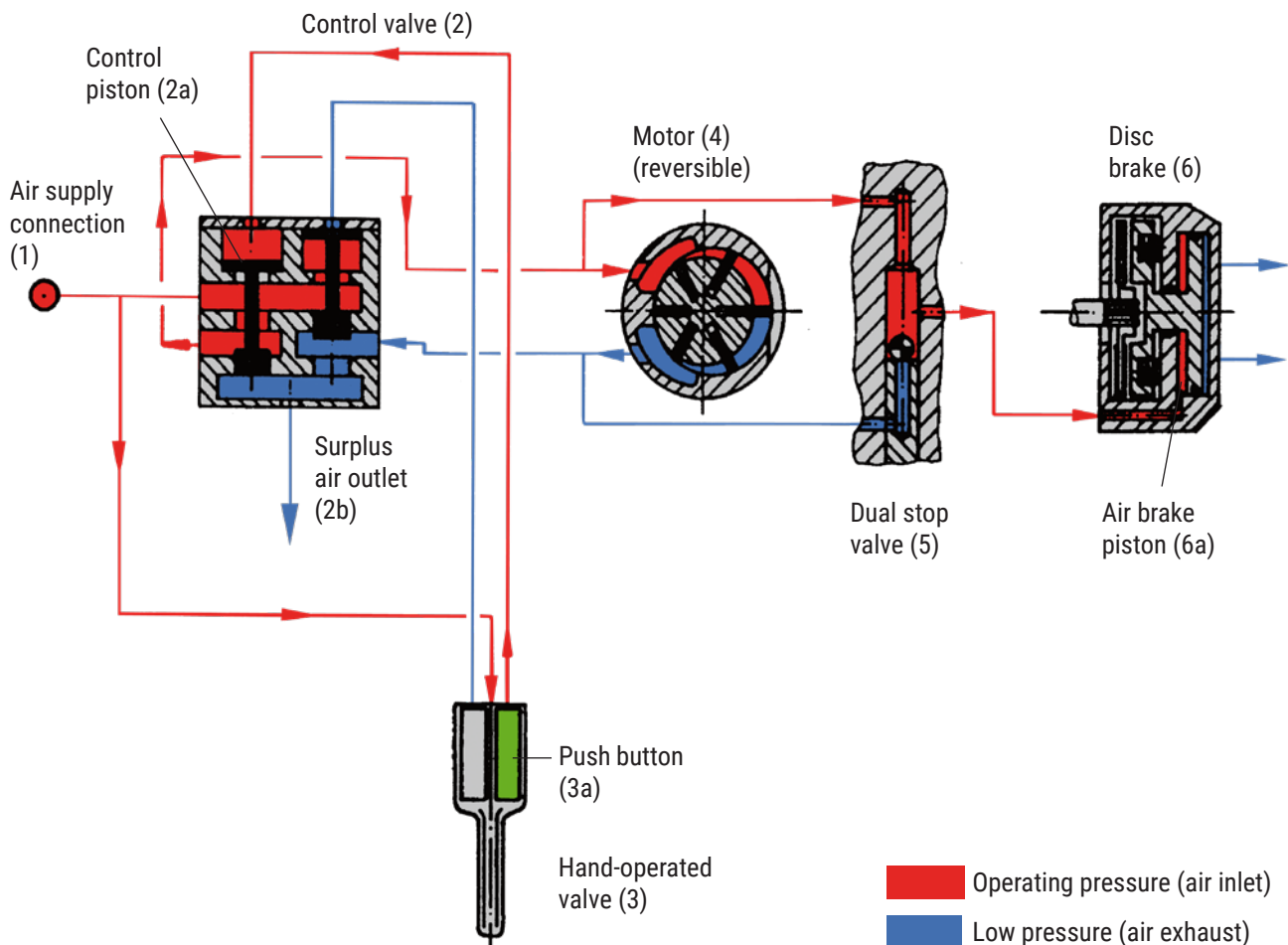

POWER / TORQUE

1. The design, the working pressure and the air consumption determine the power and the torque.

At operating pressure, the rotating speed is adjusted accordingly with the released torque.

Example: 6 bar

Torque $M = 10 \text{ Nm}$

Speed $n = 500 \text{ rpm}$

Optimum operating point approx. half of idling speed.

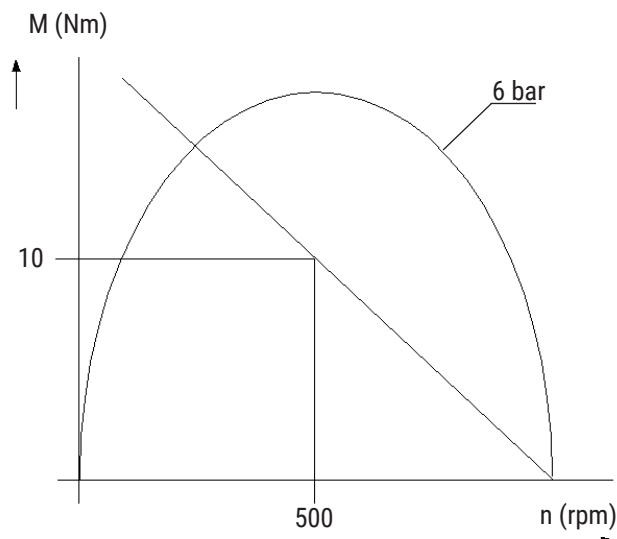

2. Reducing the operating pressure the performance curve is changed.

Other speeds can only be set by changing the air pressure.

Example: 4 bar:

Torque $M = 10 \text{ Nm}$

Speed $n = 350 \text{ rpm}$

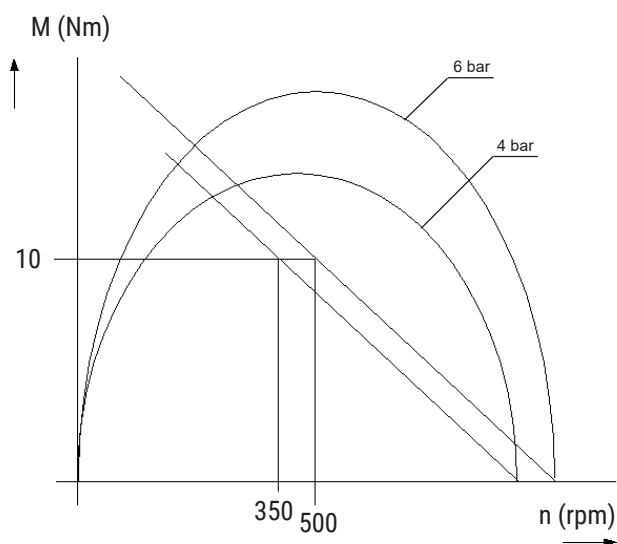

3. The torque automatically adjusts to the load.

Low loads permit high rotation speed,

while the required and produced torque is low.

If the load increases, the required torque increases too and the speed lowers.

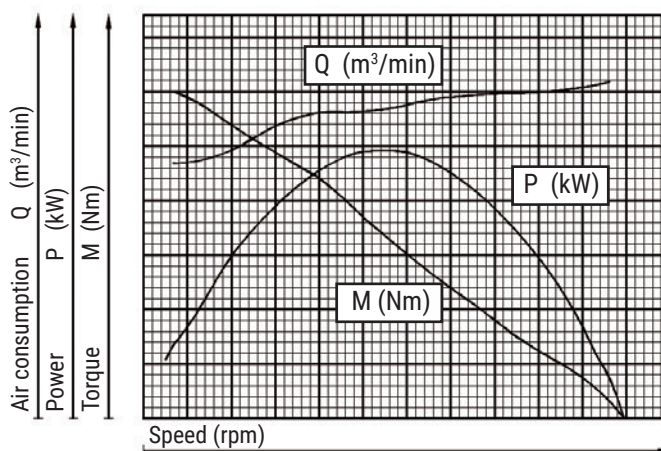

TECHNICAL DATA

SYSTEM CONCEPT

MODULAR SYSTEM

Our modular system allows multiple combinations of pneumatic gear drives.

CONTROL

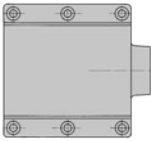
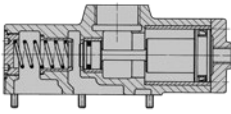
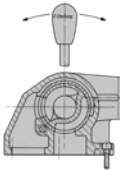
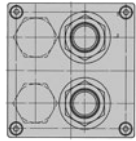
			
Connection for clockwise or anti-clockwise rotation: - non-reversible	Remote control: - pilot operated - reversible	Hand lever control: - reversible	Remote control: - direct - reversible

GEAR

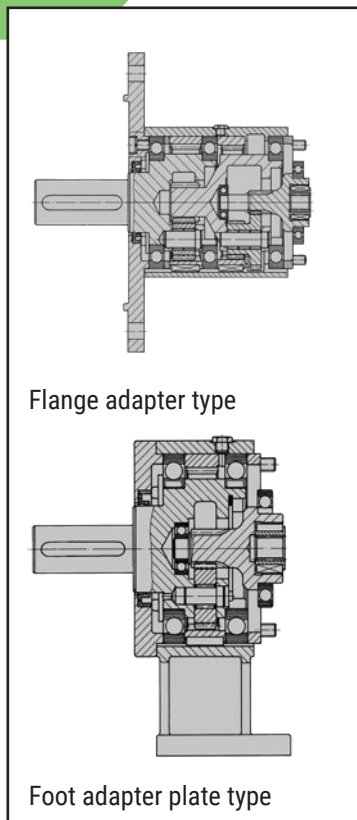

VANE-TYPE MOTOR

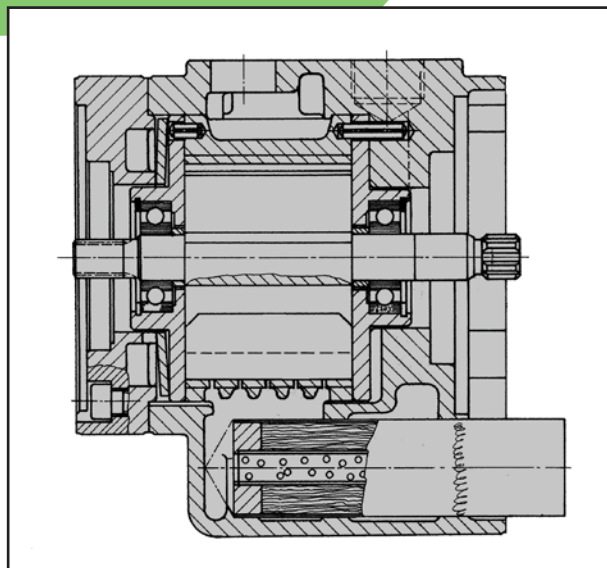

BRAKE / END COVER

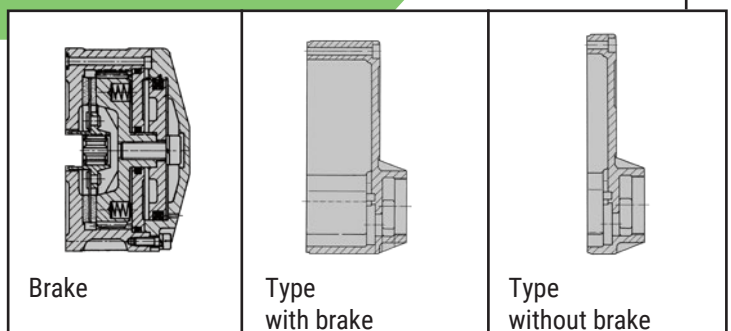

VANE-TYPE MOTORS

Our pneumatic vane-type motors are available with the following options:

- Direction of rotation right
- Direction of rotation left
- Direction of rotation reversible
- Power from 0.2 kW up to 10.0 kW
- With flange mounting
- With foot mounting
- With brake
- Without brake
- Shaft (with feather key or threaded)

Please ask for output charts and data sheets separately.

CONTROLS

Non-reversible motors:

For non-reversible motors you select the direction of rotation, i.e. clockwise or anti-clockwise (looking in front of the motor to the shaft).

With reversible motors, you choose between:

1) Hand lever control

The reversing valve is mounted directly on the motor. The reversing mechanism in the valve can be provided by a rotary valve, piston slide or two differential pistons.

2) Direct remote control

There is no actuating mechanism attached to the motor. The operating air is fed directly to the motor via two main air connections. Actuation is performed by a 4/3-way control slide.

3) Pilot-operated remote control

The main reversing valve attached to the motor housing is first actuated by one or two small pilot valves, setting the motor to the required direction of rotation.

GEARS

The fields of application for motors increase by using gears.
Spur gears, single- and multiple-speed planetary gears with variants $i=2$ up to $i=350$ are standard.

BRAKES / END COVERS

The locked disc brake is unlocked with compressed air and closes as result of spring resistance when the air supply is shut off or fails.
Mounting and shaft dimensions can be customized - if the constructive design permits.

SYSTEM CONCEPT

SYSTEM CONCEPT



Type with or without brake

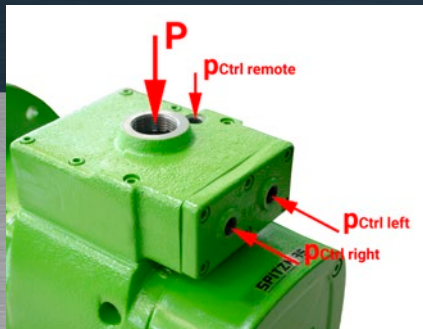

Direct hand lever control or pilot-operated remote control



Customized output shaft

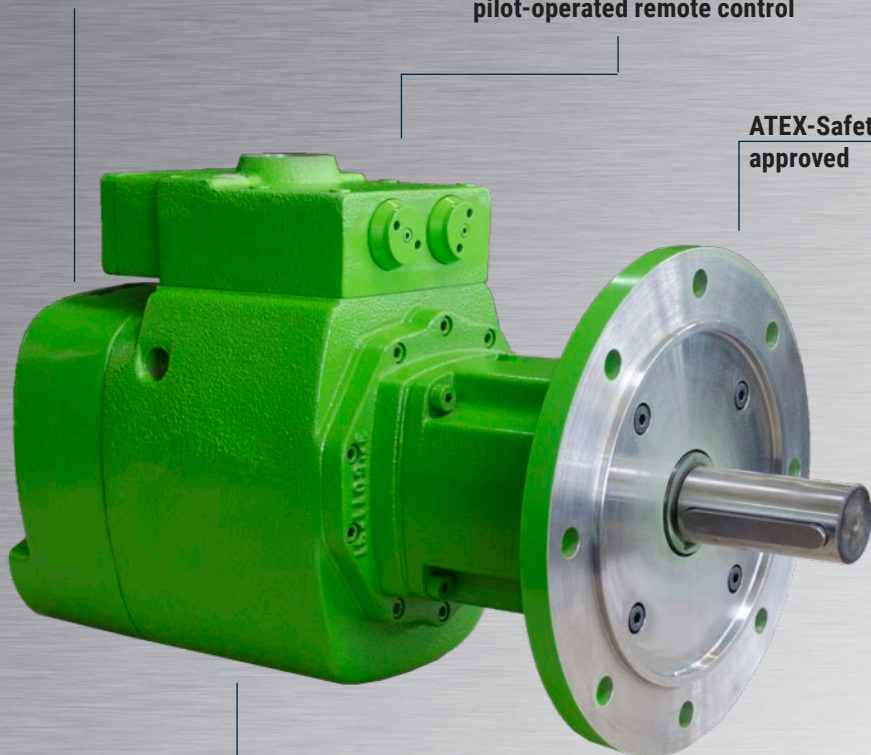

ATEX-Safety class approved

Robust vane-type motor with drive power from 0.2 up to 10.0 kW

Foot adapter plate or flange adapter type

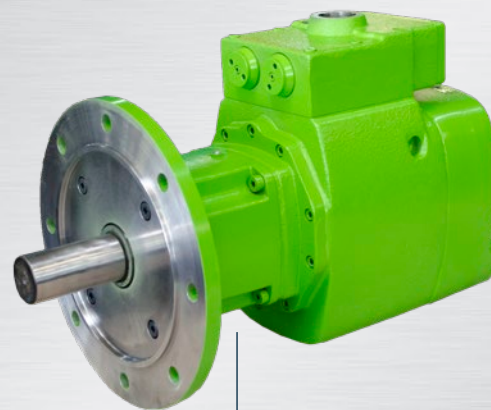

Spur gears or planetary gears with $i=2$ up to 350

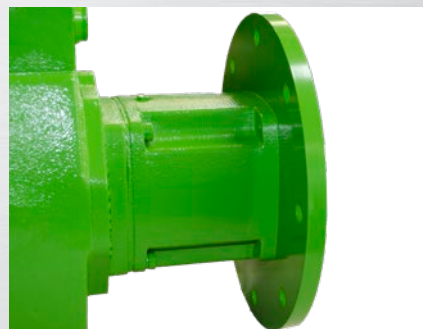
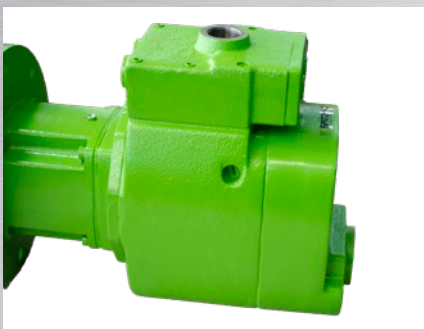

SPECIAL FEATURES

- The pneumatic vane-type motors are **robust, compact** and **usable** in a wide range of applications.
- They are **not sensitive** to dirt, moisture, temperature fluctuations or overloading.
- The pneumatic vane-type motors are **fully enclosed**. Ambient air, often infiltrated with dust and dirt, cannot penetrate the motors.
- There is **no** need for an **additional** supply of **cooling** air.
Cooling is performed **by** the decompression of the **operating air**.
During the rotation of the motor the compressed air expands and cools the motor.
- Due to the special design of the vane-type motors, they can also be **used under extreme conditions**, such as under water.
- **Overload causes no damage**. Once the overload is reduced, they starts again.
- The motors can be operated with **compressed air** or other **compressed gasses**.
- The vane motors can be adjusted for a **large speed range** by simply throttling the air volume and working pressure.
- **Fail safe disc brakes** are possible to built in for almost all motors.
- All pneumatic vane-type motors operate **spark-free** and are thus suitable for use in **hazardous environment**.
- **ATEX** conform.

ACCESSORIES

Accessories like hand control valves, pilot valves, oilers, service units, etc. will be individually combined with your pneumatic drive.

HAND CONTROL SLIDE VALVES



PILOT VALVES



OILERS



SERVICE UNITS

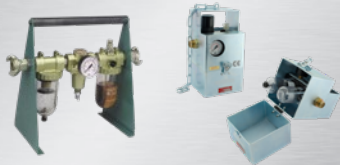

HOSES AND COUPLINGS



GREASE AND CLEANING OILS



SYSTEM CONCEPT

TECHNICAL DEMANDS

QUESTIONNAIRE

Please answer the questions as comprehensively as possible and sketch and mark the most important dimensions.

After receiving your request we will quote the right pneumatic drive to you.

The e-questionnaire is on www.spitznas.de/en/drives/pneumatic/questionnaire/

Additionally you can upload sketches, photos etc.

Company :	_____	Date :	_____
Name :	_____	Department :	_____
Street :	_____	Phone :	_____
Country :	_____	Fax :	_____
		E-Mail :	_____@_____

1. Intended use (description of purpose as complete as possible):		
2. Quantity required		Single motor: <input type="checkbox"/>
		Series: <input type="checkbox"/>
		Quantity: _____ Units
		Test model: <input type="checkbox"/>
3. Required characteristics		Power: _____ kW
		Torque: _____ Nm
		Speed under load: _____ rpm
		Max. free speed: _____ rpm
4. Type of load on motor (e.g. starting up under full load)		Starting torque: _____ Nm
5. Flow pressure at motor connection		p: _____ bar
6. Connection (inside diameter of connection hose)		Hose I/D: _____ mm
		Pipe conduit inside: _____ inches
7. Direction of rotation (looking from front at the shaft end)		Right- hand rotation (clockwise): <input type="checkbox"/>
		Left- hand rotation (anti- clockwise): <input type="checkbox"/>
		Reversible: <input type="checkbox"/>
8. Type of control		Hand-lever on motor (direct control): <input type="checkbox"/>
		Remote control, pilot controlled: <input type="checkbox"/>
		Remote control, direct via 2 connecting lines: <input type="checkbox"/>
9. Mounting		Thread mounting: <input type="checkbox"/>
		Foot mounting: <input type="checkbox"/>
		Special mounting: <input type="checkbox"/>
		Flange mounting: <input type="checkbox"/>
10. Design of motor		with brake: <input type="checkbox"/>
		without brake: <input type="checkbox"/>
11. Output shaft (e.g. shaft butt, toothing, square):		
12. Lubrication (if requested)		Service unit: <input type="checkbox"/>
		Line oiler for horizontal or vertical installation: <input type="checkbox"/>
13. Do any special regulations concerning maximum permissible sound level exist?		yes: <input type="checkbox"/>
		If yes, which? no: <input type="checkbox"/>
		max. noise level: _____ dB(A)
14. Other information:		
15. Do you have enclosed a sketch?		yes: _____ page(s) no: <input type="checkbox"/>

HYDRAULIC DRIVES PROGRAM

HYDRAULIC AXIAL PISTON PUMPS



HYDRAULIC RADIAL PISTON MOTORS



HYDROSTATIC COMPACT DRIVES



0421E